

10km 400GBASE-LR8 QSFP-DD Optical Transceiver Module OM9660LS100

ETSC's OM9660LS100 module are designed for 10km optical communication applications, and it is compliant to IEEE 802.3bs for 400GE Ethernet. This module contains 8-lane optical transmitter, 8-lane optical receiver and module management block including 2 wire serial interface. The optical signals are multiplexed to a single-mode fiber through an industry standard LC connector.



FEATURES

- QSFP-DD MSA compliant
- Compliant to IEEE 802.3bs 400GBASE-LR8
- Digital diagnostic monitoring support
- Hot pluggable 76 pin electrical interface
- 8 LAN-WDM lanes MUX/DEMUX design
- 53.125Gbit/s PAM4 Channel Electrical Serial Interface (400GAUI-8)
- Maximum power consumption 14.5W
- LC duplex connector
- Supports 425Gb/s bit rate
- Up to 10km transmission on single mode fiber
- Operating case temperature: 0°C to 70°C
- Single 3.3V power supply
- RoHS 2.0 compliant

APPLICATIONS

- 400GBASE-LR8 Ethernet
- Data Center Interconnect
- Telecom networking

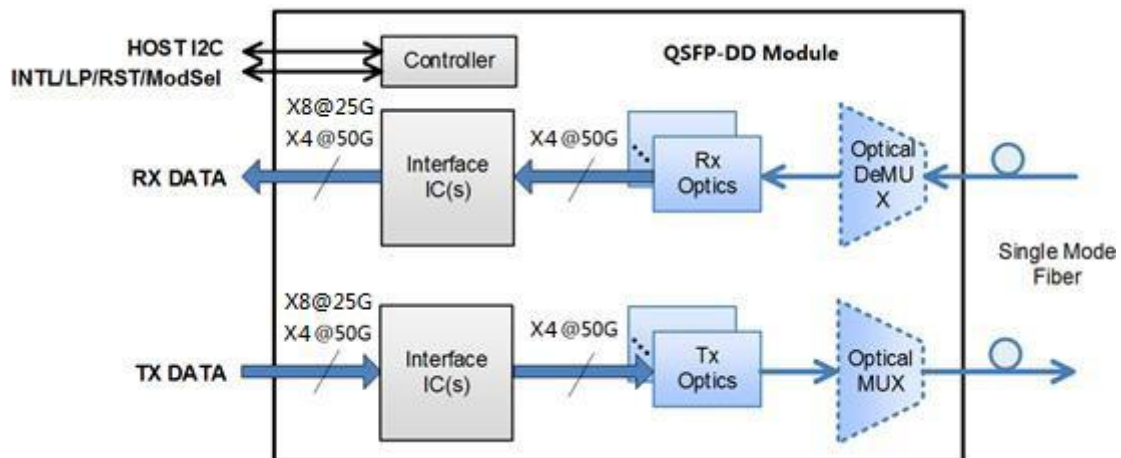

Figure 1. Transceiver Block Diagram

Pin Descriptions

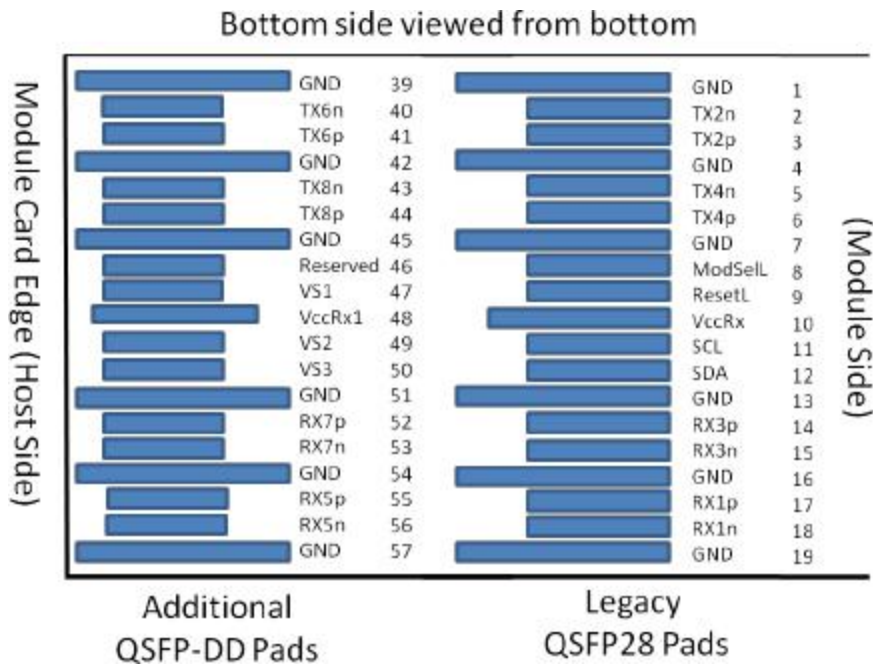
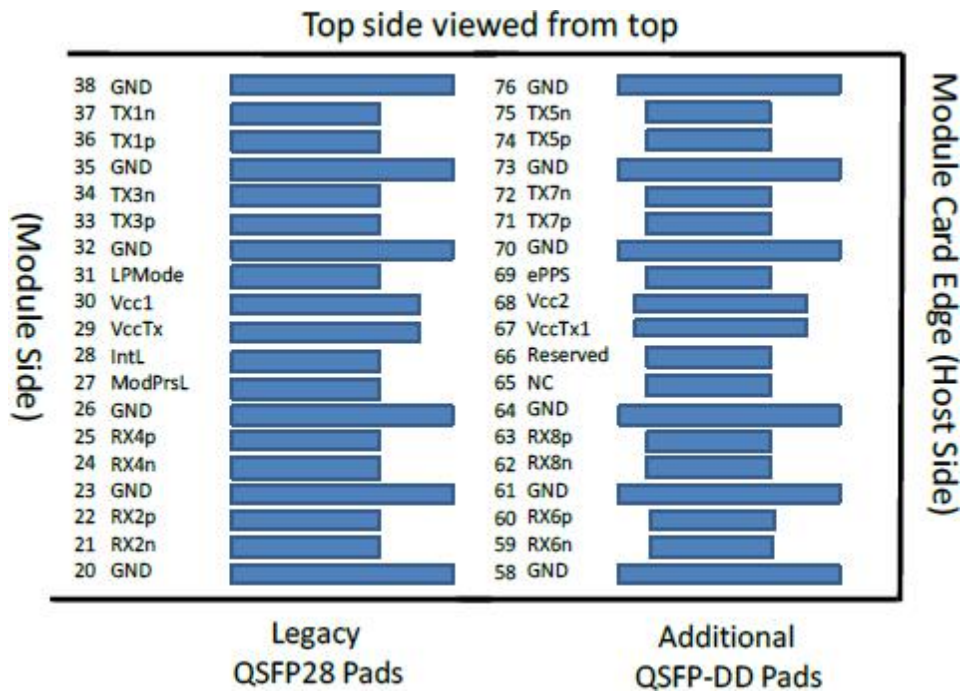

Figure 2. MSA compliant Connector

Pin	Symbol	Description	Notes
1	GND	Ground	1
2	Tx2n	Transmitter Inverted Data Input	
3	Tx2p	Transmitter Non-Inverted Data Input	
4	GND	Ground	1
5	Tx4n	Transmitter Inverted Data Input	
6	Tx4p	Transmitter Non-Inverted Data Input	
7	GND	Ground	1
8	ModSelL	Module Select	
9	ResetL	Module Reset	
10	VccRx	+3.3V Power Supply Receiver	2
11	SCL	2-wire serial interface clock	
12	SDA	2-wire serial interface data	
13	GND	Ground	1
14	Rx3p	Receiver Non-Inverted Data Output	
15	Rx3n	Receiver Inverted Data Output	
16	GND	Ground	1
17	Rx1p	Receiver Non-Inverted Data Output	
18	Rx1n	Receiver Inverted Data Output	
19	GND	Ground	1
20	GND	Ground	1
21	Rx2n	Receiver Inverted Data Output	
22	Rx2p	Receiver Non-Inverted Data Output	
23	GND	Ground	1
24	Rx4n	Receiver Inverted Data Output	
25	Rx4p	Receiver Non-Inverted Data Output	
26	GND	Ground	1
27	ModPrsL	Module Present	
28	IntL	Interrupt	
29	VccTx	+3.3V Power supply transmitter	2
30	Vcc1	+3.3V Power supply	2
31	LPMMode	Low Power mode	
32	GND	Ground	1
33	Tx3p	Transmitter Non-Inverted Data Input	
34	Tx3n	Transmitter Inverted Data Input	
35	GND	Ground	1
36	Tx1p	Transmitter Non-Inverted Data Input	
37	Tx1n	Transmitter Inverted Data Input	
38	GND	Ground	1
39	GND	Ground	1
40	Tx6n	Transmitter Inverted Data Input	
41	Tx6p	Transmitter Non-Inverted Data Input	
42	GND	Ground	

43	Tx8n	Transmitter Inverted Data Input	
44	Tx8p	Transmitter Non-Inverted Data Input	
45	GND	Ground	1
46	Reserved	For future use	3
47	VS1	Module Vendor Specific 1	3
48	VccRx1	3.3V Power Supply	2
49	VS2	Module Vendor Specific 2	3
50	VS3	Module Vendor Specific 3	3
51	GND	Ground	1
52	Rx7p	Receiver Non-Inverted Data Output	
53	Rx7n	Receiver Inverted Data Output	
54	GND	Ground	1
55	Rx5p	Receiver Non-Inverted Data Output	
56	Rx5n	Receiver Inverted Data Output	
57	GND	Ground	1
58	GND	Ground	1
59	Rx6n	Receiver Inverted Data Output	
60	Rx6p	Receiver Non-Inverted Data Output	
61	GND	Ground	1
62	Rx8n	Receiver Inverted Data Output	
63	Rx8p	Receiver Non-Inverted Data Output	
64	GND	Ground	1
65	NC	No Connect	3
66	Reserved	For future use	3
67	VccTx1	3.3V Power Supply	2
68	Vcc2	3.3V Power Supply	2
69	ePPS	Precision Time Protocol (PTP) reference clock input. It is not used.	3
70	GND	Ground	1
71	Tx7p	Transmitter Non-Inverted Data Input	
72	Tx7n	Transmitter Inverted Data Input	
73	GND	Ground	1
74	Tx5p	Transmitter Non-Inverted Data Input	
75	Tx5n	Transmitter Inverted Data Input	
76	GND	Ground	1

Notes

1. QSFP-DD uses common ground (GND) for all signals and supply (power). All are common within the QSFP-DD module and all module voltages are referenced to this potential unless otherwise noted. Connect these directly to the host board signal-common ground plane.
2. VccRx, VccRx1, Vcc1, Vcc2, VccTx and VccTx1 shall be applied concurrently. Requirements defined for the host side of the Host Card Edge Connector. VccRx, VccRx1, Vcc1, Vcc2, VccTx and VccTx1 may be internally connected within the module in any combination. The connector Vcc pins are each rated for a maximum current of 1000 mA.
3. All Vendor Specific, Reserved and No Connect pins may be terminated with 50ohms to ground on the host. Pad 65 (No Connect) shall be left unconnected within the module. Vendor specific and Reserved pads shall have an impedance to GND that is greater than 10K ohms and less than 100pF.

Absolute Maximum Ratings

It has to be noted that the operation in excess of any individual absolute maximum ratings might cause permanent damage to this module.

Parameter	Symbol	Min	Typ	Max	Unit	Notes
Maximum Supply Voltage	Vcc	-0.5	3.3	3.6	V	
Storage Temperature	Ts	-40		85	°C	
Relative Humidity	RH	10		85	%	1
Damage Threshold, each lane	THd	6.3			dBm	

Notes

1. Non-condensing

Operating Environments

Electrical and optical characteristics below are defined under this operating environment, unless otherwise specified.

Parameter	Symbol	Min	Typ	Max	Unit
Maximum Supply Voltage	Vcc	-0.5	3.3	3.6	V
Storage Temperature	Ts	-40		85	°C
Relative Humidity	RH	10		85	%

Electrical Characteristics

Parameter	Symbol	Min	Typ	Max	Unit	Note
Power dissipation			13.4	14.5	W	
Supply Current	Icc			4.625	A	Steady state
400GAUI-8 Electrical Characteristics						
Transmitter						
Signaling Rate, each lane			26.5625		GBd	PAM4
Differential Voltage pk-pk	Vin, pp			880	mV	
Common Mode Voltage	Vcm	-0.3		2.8	V	
Common Mode Noise	RMS			17.5	mV	
Differential Termination Resistance Mismatch				10	%	
Transition time	Trise/Tfall	12			ps	20%~80%
Eye Width at 10 ⁻⁶ probability	EW6	0.2			UI	
Eye Height at at 10 ⁻⁶ probability	EH6	32			mV	
Eye Linearity		0.85				
Receiver						
Signaling Rate, each lane			26.5625		GBd	PAM4
Differential Voltage pk-pk	Vout, pp			900	mV	
Transition time	Trise/Tfall	9.5			ps	20%~80%
Near-end eye width at 10 ⁻⁶ probability	EW6	0.265			UI	
Near-end eye height at 10 ⁻⁶ probability	EH6	70			mV	

Far-end eye width at 10 ⁻⁶ probability	EW6	0.2			UI	
Far-end eye height at 10 ⁻⁶ probability	EH6	30			mV	
Near-end Eye Linearity		0.85				

Notes

- 400GAUI-8 Electrical Characteristics refers to CEI-56G-VSR-PAM4 of OIF-CEI-04.0

Optical Characteristics

400GBASE-ER8 Operation (EOL, TOP = 0 to +70°C, VCC = 3.135 to 3.465 Volts)

Parameters	min	type	max	Unit	Note
Transmitter					
Signaling Speed per Lane	26.5625 ± 100 ppm			GBd	
Transmit wavelengths	1272.55	1273.54	1274.54	nm	
	1276.89	1277.89	1278.89		
	1281.25	1282.26	1283.27		
	1285.65	1286.66	1287.68		
	1294.53	1295.56	1296.59		
	1299.02	1300.05	1301.09		
	1303.54	1304.58	1305.63		
	1308.09	1309.14	1310.19		
Total Average Launch Power			13.2	dBm	
Average launch power, each lane	-2.8		5.3	dBm	
Optical Modulation Amplitude (OMA), each lane	0.2		5.7	dBm	
Extinction Ratio (ER)	3.5			dB	
Side-Mode Suppression Ratio (SMSR)	30			dB	
Transmitter and Dispersion Eye Closure for PAM4 (TDECQ), each lane			3.1	dB	
Average launch power of OFF transmitter, each lane (max)			-30	dBm	
RIN15.6OMA			-132	dB/Hz	
Optical return loss tolerance			15.6	dB	
Transmitter reflectance			-26	dB	
Receiver					
Signaling Speed per Lane	26.5625 ± 100 ppm			GBd	
Receive wavelengths	1272.55	1273.54	1274.54	nm	
	1276.89	1277.89	1278.89		
	1281.25	1282.26	1283.27		
	1285.65	1286.66	1287.68		
	1294.53	1295.56	1296.59		
	1299.02	1300.05	1301.09		
	1303.54	1304.58	1305.63		
	1308.09	1309.14	1310.19		

Average receiver power, each lane	-9.1		5.3	dBm	
Receiver power, each lane (OMA)			5.7	dBm	
Difference in receive power between any two lanes(OMA)			4.5	dB	
Damage threshold, each lane	6.3			dBm	
Receiver sensitivity (OMA), each lane			RS	dBm	1
LOS Assert	-25.1			dBm	
LOS Deassert			-11.1	dBm	
LOS Hysteresis	0.5			dB	
Receiver reflectance			-26	dB	

Notes

1. RS=max(-6.6, SECQ-8) dBm, BER@2E-4

EEPROM Definitions

Refer to QSFP-DD Common Management Interface Specification Rev 4.0.

Digital Diagnostic Monitoring Functions

OM9660LS100 support the I2C-based Diagnostic Monitoring Interface (DMI) defined in document QSFP-DD Common Management Interface Specification Rev 4.0. The host can access real-time performance of transmitter and receiver optical power, temperature, supply voltage and bias current.

Performance Item	Related Bytes	Monitor Error	Notes
Module temperature	14 to 15 at Page low	+/-3°C	1, 2
Module voltage	16 to 17 at Page low	< 5%	2
LD Bias current	170 to 185 at Page 11h	< 10%	2
Transmitter optical power	154 to 169 at Page 11h	< 3dB	2
Receiver optical power	186 to 201 at Page 11h	< 3dB	2

Notes

1. Actual temperature test point is fixed on module case around Laser Array.
2. Full operating temperature range

Alarm and Warning Thresholds

OM9660LS100 support alarms function, indicating the values of the preceding basic performance are lower or higher than the thresholds.

Performance Item	Alarm Threshold Bytes(A0[03] memory)	Unit	Low threshold	High threshold
Temp Alarm	128 to 131 at Page 02	-10 °C	80 °C	Temp Alarm
Temp Warning	132 to 135 at Page 02	0 °C	70 °C	Temp Warning
Voltage Alarm	136 to 139 at Page 02	2.97 V	3.63 V	Voltage Alarm
Voltage Warning	140 to 143 at Page 02	3.135 V	3.465 V	Voltage Warning
TX Power Alarm	176 to 179 at Page 02	-4.8 dBm	7.3 dBm	TX Power Alarm
TX Power Warning	180 to 183 at Page 02	-2.8 dBm	5.3 dBm	TX Power Warning
RX Power Alarm	192 to 195 at Page 02	-12.1 dBm	7.3 dBm	RX Power Alarm
RX Power Warning	196 to 199 at Page 02	-10.1 dBm	5.3 dBm	RX Power Warning

Mechanical Specifications

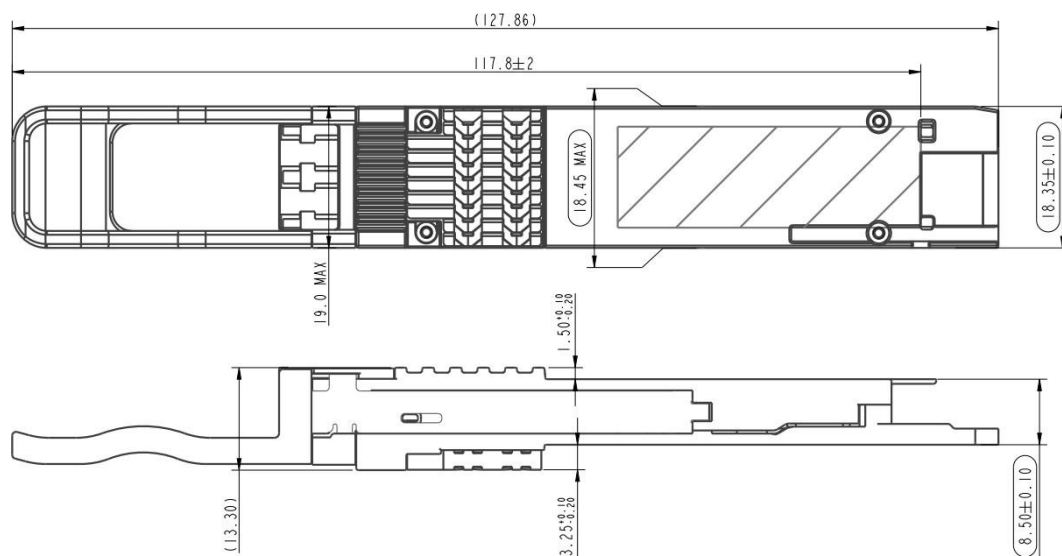

Figure 3. OM9660LS100 Mechanical Dimensions

Regulatory Compliance

Feature	Agency	Standard	Performance
Safety	NRTL	UL 62368-1 CAN/CSA C22.2 No. 62368-1	NRTL recognized component for US and CAN
	TUV	EN 62368-1 IEC 60825-1:2014 EN 60825-1:2014 IEC 60825-2:2004+A1:2006+A2:2010 EN 60825-2:2004+A1:2006+A2:2010	TUV certificate
	FDA	U.S. 21 CFR 1040.10	FDA/CDRH certified with accession number according to Laser Notice 56
Electromagnetic Compatibility	Radiated emissions	EMC Directive 2014/30/EU EN 55032 CISPR 32 FCC rules 47 CFR Part 15 ICES-003 AS/NZS CISPR 32	Class B digital device with a minimum -6dB margin to the limit when tested with a metal enclosure. Final margin may vary depending on system application, good system EMI design practice, ie: suitable metal enclosure and well-bonding, is required to achieve Class B margins at the system level. Tested frequency range: 30 MHz to 40 GHz or 5th harmonic (5 times the highest frequency), whichever is less.
	ESD	EMC Directive 2014/30/EU EN 55035 CISPR 35 IEC/EN 61000-4-2	Withstands discharges of ± 8 kV contact, ± 15 kV air.
	Radiated immunity	EMC Directive 2014/30/EU EN 55035 CISPR 35 IEC/EN 61000-4-3	Field strength of 10 V/m from 80 MHz to 6 GHz.
Restriction of Hazardous Substances	RoHS	EU Directive 2011/65/EU (EU) 2015/863	

ESD Design

Normal ESD precautions are required during the handling of this module. This transceiver is shipped in ESD protective packaging. It should be removed from the packaging and otherwise handled in an ESD protected environment utilizing standard grounded benches, floor mats, and wrist straps.

Parameter	Threshold value	Notes
ESD of high-speed pins	1KV	Human Body Model
ESD of low-speed pins	1KV	Human Body Model
Air discharge during operation	15KV	
Direct contact discharges to the case	8KV	

Safety Specification Design



Do not look into fiber end faces without eye protection using an optical meter (such as magnifier and microscope) within 100 mm, unless you ensure that the laser output is disabled. When operating an optical meter, observe the operation requirements.

CAUTION: Use of controls or adjustments or performance of procedures other than those specified herein may result in hazardous radiation exposure.

Attention – L'utilisation des commandes ou réglages ou l'exécution des procédures autres que celles spécifiées dans les présentes exigences peuvent être la cause d'une exposition à un rayonnement dangereux.

Ordering Information

Part Number	Description
OM9660LS100	400GBASE-LR8 QSFP-DD, Pull-tap, Single rate, refer to Figure 3